

Base Connector SWS

The **Base Connector SWS200** is the optimal connection between the robot and its base. It takes only seconds to change out the robot or place it into a different application. The intuitive and safe operation will make your robot more flexible.

The **Base Connector SWS200** is compatible with all light robots / cobots with a max payload of approximately 16 kg and a robot weight of approximately 50 kg. Please inform us of the robot manufacturer to ensure the correct drill hole pattern.



Base Connector SWS200

The **Base Connector SWS200** is the ideal mechanical connection for light robots. The intuitive operation is easy and does not require any tools.

The SWS upper assembly, as depicted in the drawing, is mounted to the base of the robot. The lower assembly is mounted to the work surface.

Pos.	Description
1	Robot
2	ZG-VKS160-SW20 Square Socket Key
3	G-SWS200-2O-N-LBR10 SWS Connector Upper assembly
4	G-SWS200-2U-N SWS Connector Lower assembly

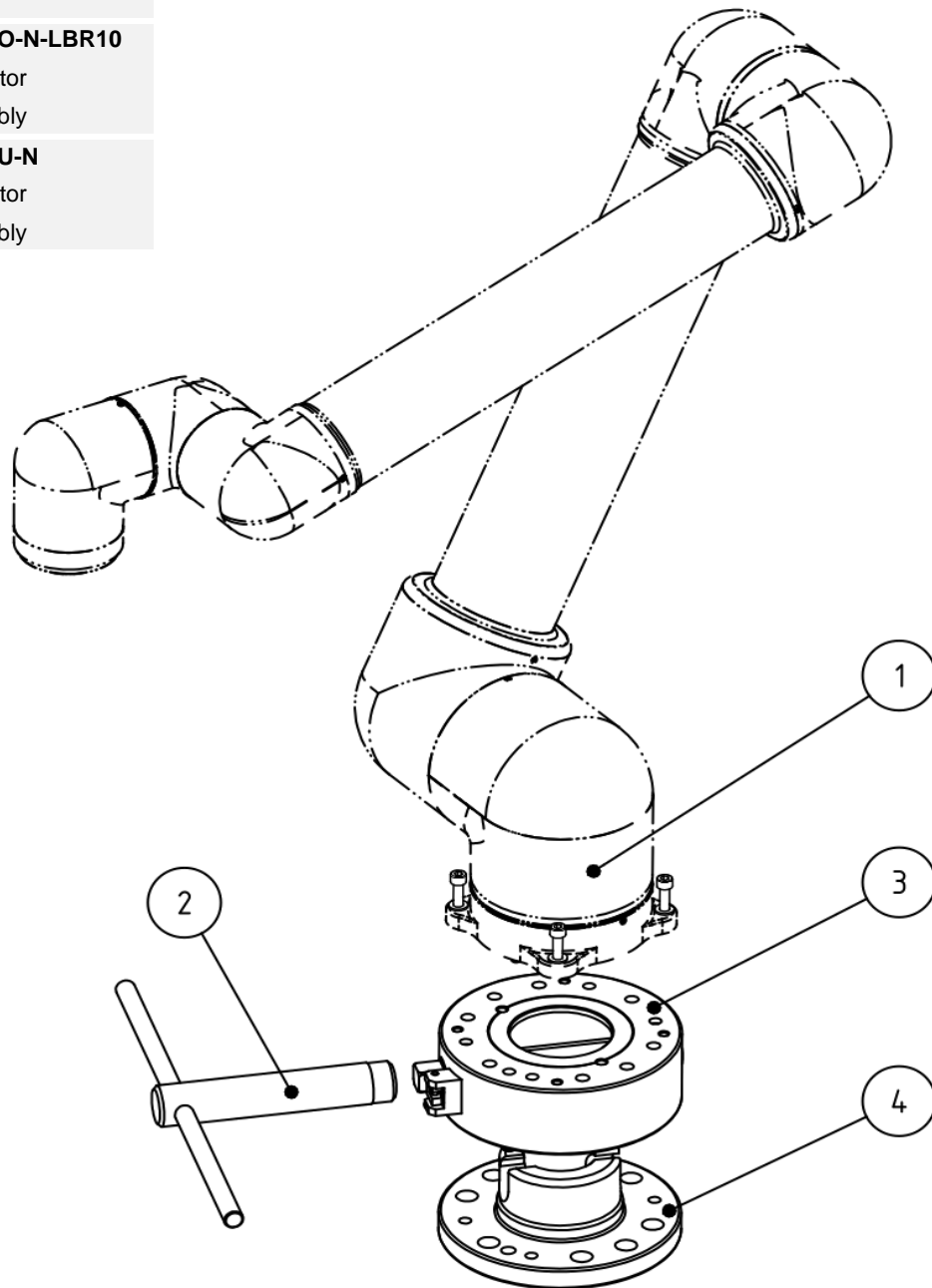

Base Connector SWS200

Technical specifications



Operating mode:

By rotating the semi-cylindrical bolt by 180° the upper assembly (1) and the lower assembly (2) are braced in a form-closed manner

Advantages:

- Without hand lever, thereby low interference contours
- High repeat accuracy +/- 0.02 mm
- Optional connection of a power coupling MEK for electrical and pneumatical ducts
- Holds up to 10,000 changing cycles
- During locking, the lower assembly is pulled around the locking stroke
- Interface according to DIN EN ISO 9409-1
- Low dead weight due to the combination of steel and aluminum

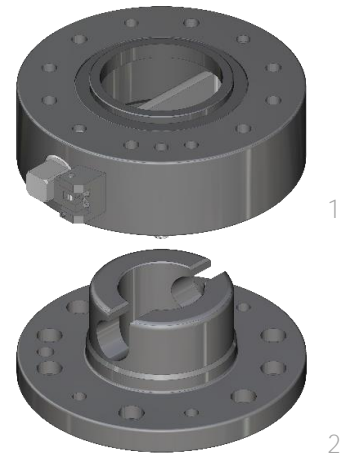

Technical specifications		SWS200
Basic material		steel, nitrated + Al
External diameter x Height [mm]		200 x 85
Pitch circle diameter [mm]		160
Repeat accuracy +/- [mm]		0,02
Tension Fz [N]		14.500
Compression -Fz [kN]		1.480
Torsion Mz [Nm]		1.250
Bending Mx, My [Nm]		1.350
Mass [kg]	upper assembly	6,4
	lower assembly	6
Recommended load [kg] *		50
Locking moment VM [Nm]		5 - 35
Locking stroke VH [mm]		0 - 10
Operating temperature range [°C]		-30 to +120
<small>* This guideline applies to the following assumptions: Acceleration: 3m/s², gravity distance: 1.000 mm, 1,7 times safety</small>		

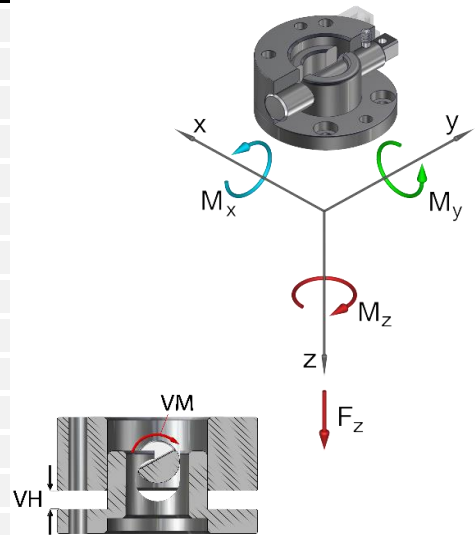

Quick change system Ø200...

drilled according to ISO, steel, nitrated, with pre-centring...

G-SWS200-20-N-LBR10	upper assembly, anti-rotation-protection, 4 x M8 L
G-SWS200-20EN-LBR10	upper assembly, E-Mounting, anti-rotation-prot.
G-SWS200-2U-N	lower assembly
G-SWS200-2UEN	lower assembly, E-Mounting

Square socket key...

ZG-VKS160-SW20	for SW 20
----------------	-----------

Pos.	Description
1	Upper assembly
2	Semi-cylindrical bolt
3	Setscrew
4	Index pin
5	Anti-rotation lock
9	Lower assembly

