

Dear customer,

Congratulations!

You have chosen the best product we know how to make with our 30 years of experience and passion for precision.

Please follow the instructions in this manual to avoid mistakes and save time.

In case you need further information or you have further requests we will be glad to be at your disposal.

With best regards,

Your GRIP GmbH

GRIP GmbH Handhabungstechnik  
Alter Hellweg 70  
44379 Dortmund, Germany

Tel. +49 231 96450 01

info@grip-gmbh.com  
www.grip-gmbh.com



## MEK Energy Coupling (for MGW)

	<b>Contents</b>	<b>Page</b>
<b>1</b>	Operation	2
<b>2</b>	Safety	2
	<b>2.1</b> Symbol	2
	<b>2.2</b> Intended use	2
	<b>2.3</b> Environmental and operating conditions	2
	<b>2.4</b> Safety indication	2
<b>3</b>	Warranty	3
<b>4</b>	Scope of delivery	3
<b>5</b>	Technical data	3
<b>6</b>	Assembly	3
<b>7</b>	Maintenance and care	4
	<b>7.1</b> Disassembly	4
	<b>7.2</b> Torque specifications	4
	<b>7.3</b> Compressed air connection	4
<b>8</b>	Parts list	4
	<b>8.1</b> Spare and wear parts	4
<b>9</b>	Exploded view	5
<b>10</b>	EC-Declaration of incorporation	6

## 1 Operation

The upper assembly of the MEK is mounted on the upper assembly of the MGW or SWS, the lower assembly of the MEK corresponding to the lower assembly. The mechanical connection of two components by means of a change system is extended by the MEK, now the pneumatic and electrical lines are coupled or decoupled parallel. Time-intensive disconnection of cables and hoses is no longer necessary.

Pneumatic and electrical connectors are integrated in both halves, which are specially designed for frequent plug connections and low joining forces. The MEK are graded in sizes according to the GRIP change systems.

## 2 Safety

### 2.1 Symbol



This symbol indicates possible hazards to persons or the MEK Energy Coupling.

### 2.2 Intended Use

The MEK Energy Coupling series has been designed to operate pneumatic and / or electrical equipment. The module is intended for installation in a machine. The requirements of the applicable instructions must be considered and adhered to. The unit may only be used in the context of its technical specifications.

### 2.3 Environmental and operating conditions

Use this unit only in dry and splash-proof environments at room temperature as well as within the application parameters defined in the technical specifications. If this is not the case, warranty cannot be accepted. Exceptions are units designed especially for the respective conditions.

### 2.4 Safety indication

Dangers may arise from the unit, if:

- the product is not installed or inserted properly,
- the system is not used for its intended purpose,
- the safety and installation notes are not observed.

Everyone who is responsible for assembly, commissioning and maintenance must read and understand the complete operating instructions. Improper use, which affects the function and operational safety of the MEK Energy Coupling, is prohibited.



#### **NOTICE!**

**The unit may only be operated if the machine in which the unit is installed complies with the relevant provisions of the Machinery Directive 2006-42-EC.**



#### **CAUTION!**

**Before carrying out assembly, alteration, maintenance or adjustment, remove the power supply and carry out the necessary work outside the danger zone.**

### 3 Warranty

If the product is used as intended in 1-shift operation the warranty is valid for 24 months from the ex-works delivery date under observance the mandatory maintenance and lubrication intervals and the given operating conditions. Generally parts touching the work piece and wear parts are not part of the warranty. Wear parts are listed in chapter 8.1. The unit is considered to be defective if its basic function "Feeding through" is no longer functioning.

### 4 Scope of Delivery

- MEK as painted in Image 4 depending on the order number of the upper or lower assembly.

### 5 Technical Data

Behold technical data sheets: TD-MEK063-EN, TD-MEK080-EN, TD-MEK100-EN, TD-MEK125-EN, TD-MEK160-4P-1E-EN, TD-MEK160-8P-1E-EN, TD-MEK160-8P-2E-EN, TD-MEK160-10P-4E-EN, TD-MEK160-22P-4E-EN, TD-MEK200-EN

### 6 Assembly

1. To connect the pneumatic feedthroughs, the customer-side hoses, with the corresponding internally calibrated diameters, must be pushed onto the hose nipples and bushes (pos. 5 and 6).
2. To connect the electrical feedthroughs, unscrew the screwed cable gland (pos. 9).
3. The complete insulation elements (pos. 7 and 8) can be removed to solder the connections. Attention! The solder contacts are mounted in a floating manner, their movement margin may not be restricted after soldering (for example by cables which are too thick or by shrink tubing).
4. Once the connections have been completed, the insulating body must be pushed back into the housing as far as it will go (pos. 1 or 4).
5. To adjust the upper and lower assemblies, the upper assembly (pos. 1 reference part) has to be assembled completely. Subsequently, the lower assemblies (pos. 4) are mechanically joined and the insulating body of the lower assembly is aligned by simple plugging onto the contacts of the upper assembly. In this case, only one position is possible (polarity-proof insulating body).
6. If several lower assemblies are used, this process is repeated accordingly, the upper assembly is always the reference piece.

The electrical plug (pos. 8) belongs to the MEK upper assembly, the electrical socket (pos. 7) belongs to the MEK lower assembly.

Image 1



## 7 Maintenance and care

The O-rings (item 2) should be slightly lubricated.

### 7.1 Disassembly of the MEK

(See Image 2 and Image 3)

1. Remove all compressed air lines.
2. Loosen the mounting screws (pos. 10).
3. Fully unscrew the cable glands (pos. 9).
4. Remove the O-ring (pos. 2).
5. Clean all parts thoroughly. Inspect for wear and defects.
6. Grease all sealing surfaces.
7. Lubricate all mating surfaces.

For assembly, reverse the order.

### 7.2 Torque specifications

M2,5 – 0,5 Nm; M3 – 1,0 Nm; M4 – 2,0 Nm; M5 – 4,0 Nm

### 7.3 Compressed air connection

Requirements for compressed air according to ISO 8573-1: 6 4 4.

## 8 Parts List

Pos.	Description	Quantity
1	Upper assembly	1
2	O-ring	1
3	Cylindrical pin	1
4	Lower assembly	1
5	Plug connector	4 / 8
6	Plug nipple	4 / 8
7	Insulating body with bush	1
8	Insulating body with pins	1
9	Skintop cable gland Pg11	2
10	Mounting screw	4

### 8.1 Spare and wear parts, depending on size

Pos.	Description	Order-No.	Quantity
2	O-Ring	EG-MEK-OR...x...	1
5	Plug connector	EG-MEK-SB...	4 / 8
6	Plug nipple	EG-MEK-SN...	4 / 8
7	Insulating body with bush	EG-MEK-IKB...	1
8	Insulating body with pins	EG-MEK-IKS...	1
9	Skintop cable gland Pg11	EG-MEK-PG11	1

9 Explosion view

Image 2

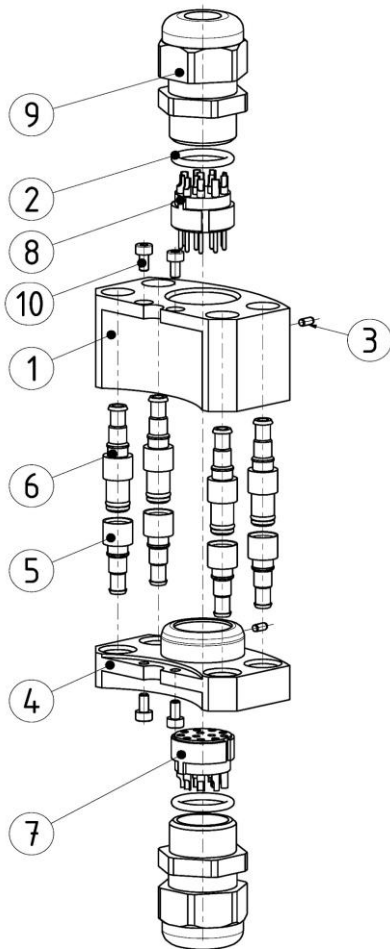

G-MEK-...-O-4PK4-1E

Image 3

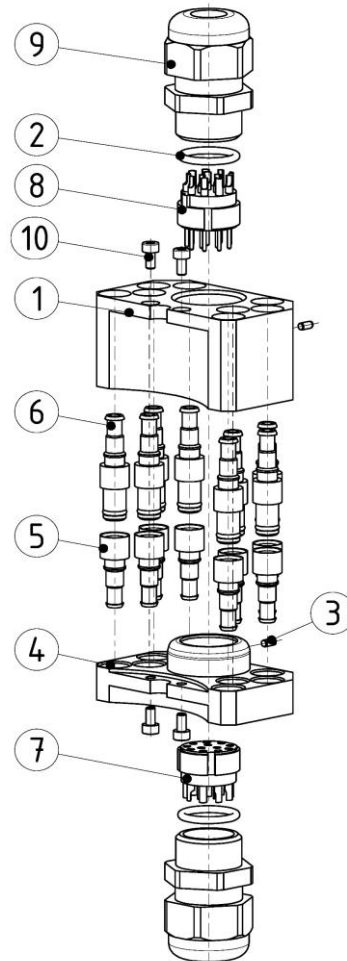

G-MEK-...-O-8PK4-1E

Image 4



Upper assembly

Lower assembly

**10 EC - Declaration of incorporation**

according to the Machinery Directive 2006/42/EC

The producer / distributor GRIP GmbH Handhabungstechnik  
Alter Hellweg 70  
D-44379 Dortmund, Germany

hereby declares that the following products

**Product designation:** Multi energy coupling (MEK)

**Functional description:** Component for carrying compressed air and electrical signals

**Type designation:** G-MEK063 to 200

The provisions of the above-mentioned directives -including their effective amendments- comply with the time of the declaration.

He further states that the following essential requirements of the Machinery Directive 2006/42/EG were applied and observed:  
annex I, numerics: 1.1.2; 1.1.3; 1.1.5; 1.3.2; 1.7.4

He further states that the specific technical documentation has been drawn up in accordance with annex VII, Part B.

The following harmonized standard has been applied:

EN ISO 12100-1:2003 Safety of Machinery- Basic concepts, general principles for design- Part 1:  
Basic terminology and methodology (ISO 12100-1:2003)

EN ISO 12100-2:2003 Safety of Machinery- Basic concepts, general principles for design- Part 2:  
Technical principles (ISO 12100-2:2003)

In the case of reasoned requests, the specific documents shall be sent to the national authorities as follows: Post

The product mentioned above may only be put into operation if it has been established applicable that the unit, into which the above-mentioned product is to be incorporated, complies with the provisions of the Machinery Directive 2006/42 / EC.

Authorized representative: Dipl.-Ing. (FH) Hasan Canti

Location: Dortmund  
Date: 15.08.2025



Dipl.-Ing. (FH) Hasan Canti  
Executive Director