

Dear customer,

Congratulations!

You have chosen the best product we know how to make with our 30 years of experience and passion for precision.

Please follow the instructions in this manual to avoid mistakes and save time.

In case you need further information or you have further requests we will be glad to be at your disposal.

With best regards,

Your GRIP GmbH

GRIP GmbH Handhabungstechnik
Alter Hellweg 70
44379 Dortmund, Germany

Tel. +49 231 96450 01

info@grip-gmbh.com
www.grip-gmbh.com



SEK energy feed-through (for SHW)

	Contents	Page
1	Operation	2
2	Safety	2
	2.1 Symbol	2
	2.2 Intended use	2
	2.3 Environmental and operating conditions	2
	2.4 Safety indication	2
3	Warranty	3
4	Scope of delivery	3
5	Technical data	3
6	Assembly	3
7	Maintenance and care	4
	7.1 Disassembly	4
	7.2 Torque specifications	4
8	Parts list	4
	8.1 Spare and wear parts	4
9	Exploded view	5
10	EC-Declaration of incorporation	6

1 Operation

The upper assembly of the SEK energy feed-through is attached to the upper assembly of the SHW Connector, according to this the lower assembly of the SEK is attached to the lower assembly of the SHW.

The mechanical connection of two components using the SHW is extended by the SEK in a way that electrical lines can be coupled or decoupled in parallel. Time-consuming disconnection of the cables is no longer necessary.

Electrical connectors are integrated into both halves, which are especially designed for frequent plug connections and low mating forces. The SEK are graded according to the GRIP change systems.

2 Safety

2.1 Symbol



This symbol indicates possible hazards to persons or the SEK energy feed-through.

2.2 Intended use

The SEK energy feed-through series has been designed for the implementation of electrical systems. The system is intended for the installation in a machine. The requirements of the applicable instructions must be considered and adhered to. The unit may only be used in the context of its technical specifications.

2.3 Environmental and operating conditions

Use this unit only in dry and splash-proof environments at room temperature as well as within the application parameters defined in the technical specifications. If this is not the case, warranty cannot be accepted. Exceptions are units designed especially for the respective conditions.

2.4 Safety indication

Dangers may arise from the unit, if:

- the product is not installed or inserted properly,
- the system is not used for its intended purpose,
- the safety and installation notes are not observed.

Everyone who is responsible for assembly, commissioning and maintenance must read and understand the complete operating instructions. Improper use, which affects the function and operational safety of the SEK energy feed-through, is prohibited.



NOTICE!

The unit may only be operated if the machine in which the unit is installed complies with the relevant provisions of the Machinery Directive 2006-42-EC.



CAUTION!

Before conducting assembly-, structural alteration-, maintenance- and installation work remove the power supply and conduct the necessary work outside the danger zone.

3 Warranty

If the product is used as intended in 1-shift operation the warranty is valid for 24 months from the ex-works delivery date under observance the mandatory maintenance and lubrication intervals and the given operating conditions. Generally parts touching the work piece and wear parts are not part of the warranty. Wear parts are listed in chapter 8.1. The unit is considered to be defective if its basic function "feeding through" is no longer functioning.

4 Scope of delivery

- SEK as shown in Image 3 depending on the order number of the upper or lower assembly.

5 Technical Data

Behold technical data sheets: TD-SEK100-EN, TD-SEK125-EN, TD-SEK160-EN

6 Assembly

1. To connect the electrical operations, the caps (pos. 2) have to be unscrewed.
2. The complete insulating bodies (pos. 4 and 12) can be removed to solder the connections. Attention! The solder contacts are mounted in a floating manner, their range for movement may not be restricted after soldering (for example by cables which are too thick or by shrink tubing).
3. Once the connections have been completed, the insulating body must be pushed back into the housing as far as it will go (pos. 1 or 4).
4. To adjust the upper and lower assemblies, the upper assembly (pos. 1) is to be assembled completely. After that the lower assemblies (pos. 4) are mechanically joined and the insulating body of the lower assembly is aligned by simple plugging onto the contacts of the upper assembly. In this case, only one position is possible (polarity-proof insulating body).
5. If several lower assemblies are used, this process is repeated accordingly, the upper assembly is always the reference piece.

The electrical plug (pos. 4) belongs to the upper assembly of the SEK, the electric socket (pos. 12) belongs to the lower assembly of the SEK.

Image 1

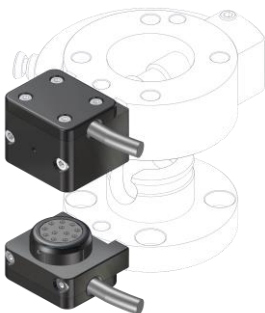

7 Maintenance and care

The O-rings (pos. 5) should be slightly lubricated.

7.1 Disassembly of the SEK

(behold Image 2)

1. Loosen the erection screw (pos. 7).
2. Loosen the screws of the cap (pos.8) completely.
3. Remove the caps (pos.2).
4. Remove the insulating body (pos. 4 and 12) with distance bush (pos. 3 and 11).
5. Clean all parts thoroughly. Inspect for wear and defects.
6. Lubricate all mating surfaces.
7. Replace all seals.

For assembly, reverse the order.

7.2 Torque specifications

M3 – 1,5 Nm; M5 – 4 Nm

8 Parts list

Pos.	Description	Quantity
1	Upper assembly 1E	1
2	Cap	2
3	Distance bush upper assembly	1
4	Insulating body with pins	1
5	O-ring	1
6	Cylindrical pin	1
7	Erection screw	4
8	Screw for Cap	8
9	Cable on the robot side	1
10	Lower assembly 1E	1
11	Distance bush lower assembly	1
12	Insulating body with bushings	1
13	Cable on the gripper side	1

8.1 Spare and wear parts

Pos.	Description	Order-No.	Quantity
4	Insulating body with pins	EG-MEK-IKS12	1
5	O-ring	EG-SEK-OR..x.	1
12	Insulating body with bushings	EG-SEK-IKB12	1

9 Exploded view

Image 2

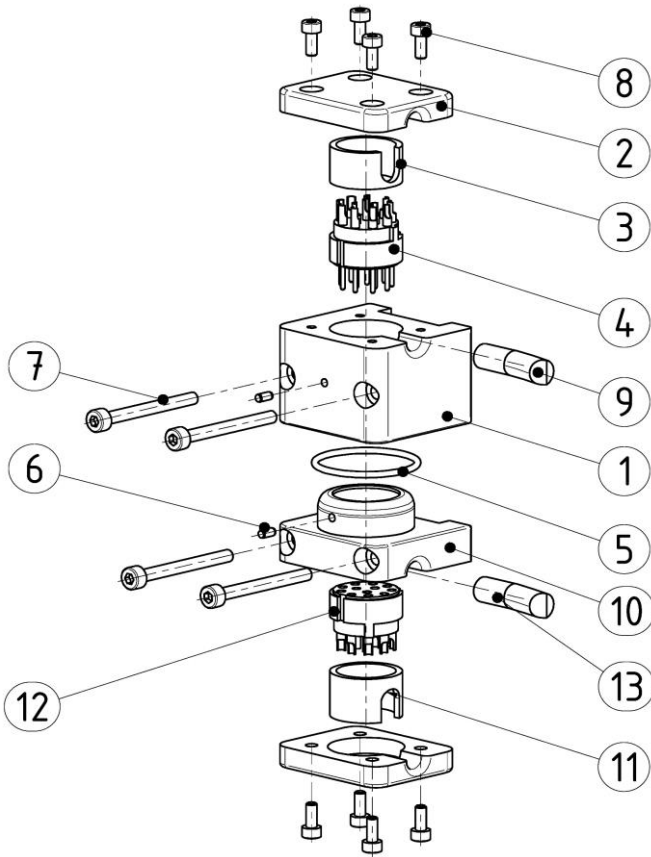
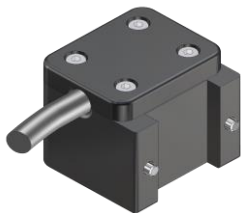

Image 3



Upper assembly



Lower assembly

10 EC - Declaration of incorporation

according to the Machinery Directive 2006/42/EC, annex II B

The producer / distributor GRIP GmbH Handhabungstechnik
Alter Hellweg 70
D-44379 Dortmund, Germany

hereby declares that the following products

Product designation: SEK energy feed-through (SEK)

Functional description: Component to conduct electrical signals

Type designation: G-SEK100 to 160

The provisions of the above-mentioned directives- including their effective amendments- comply with the time of the declaration.

He further states that the following essential requirements of the Machinery Directive 2006/42/EC were applied and observed:
annex I, numerics: 1.1.2; 1.1.3; 1.1.5; 1.3.2; 1.7.4

He further states that the specific technical documentation has been drawn up in accordance with annex VII, Part B.

The following harmonized standard has been applied:

EN ISO 12100-1:2003 Safety of Machinery- Basic concepts, general principles for design- Part 1:
Basic terminology and methodology (ISO 12100-1:2003)

EN ISO 12100-2:2003 Safety of Machinery- Basic concepts, general principles for design- Part 2:
Technical principles (ISO 12100-2:2003)

In the case of reasoned requests, the specific documents shall be sent to the national authorities as follows: Post

The product mentioned above may only be put into operation if it has been established applicable that the unit, into which the above-mentioned product is to be incorporated, complies with the provisions of the Machinery Directive 2006/42 / EC.

Authorized representative: Dipl.-Ing. (FH) Hasan Canti

Location: Dortmund
Date: 24.01.2023



Dipl.-Ing. (FH) Hasan Canti
Executive Director